

03

The Smallpeice Trust
ENGINEERING
@ SCHOOL

The Parachute Challenge

Subject: STEM/Engineering

Year group: 3-6



   #EngineeringAtSchool

PARACHUTE TEACHER GUIDANCE

This activity can be used as one of eight towards students obtaining the CREST SuperStar Award.

What Is CREST?



CREST is a nationally recognised scheme for student-led project work in the STEM subjects (science, technology, engineering and maths).

CREST gives young people aged 5–19 the chance to choose their own subject and methodology when completing their hands-on investigation.

CREST provides activities and project ideas for a range of ages, group size and abilities. From off-the-shelf, one-hour long challenges through to large-scale, student-led projects of over 70 hours work or more, CREST can be done by anyone.

What is CREST SuperStar?

SuperStar level is designed to be easy-to-run and low-cost for children typically aged 7–11 years. Children gain an Award by completing eight challenges.

You can download a CREST SuperStar passport template for your students to track their progress once you create an account via

www.crestawards.org/crest-superstar

ENTRY FEE per child: £1 UK / £4 International*

Within four weeks of payment, you will receive certificates and fabric badges to give out to your class.

LENGTH OF LESSON: 1-2 HOURS

How to make your Parachute:

<https://bit.ly/3dxYDmo> 



LESSON OVERVIEW

Students work in teams of “engineers” to design and build their own parachute out of everyday items. They test their parachute, evaluate their results, and present to the class.

Learning Objectives

During this lesson, students will:

- Design and construct a parachute
- Measure the height and velocity
- Test and refine their designs
- Communicate their design process and results

Learning Outcomes

- To consolidate concept of air resistance/drag
- To use “metres per second” (m/s) as the unit of speed
- To design and build models by using different materials and to test selected functional characteristic of the model built with the chosen materials

Key Vocabulary:

FORCES, AIR RESISTANCE/ DRAG, GRAVITY, HEIGHT, FRICTION, SPEED/VELOCITY

Curriculum links

SCIENCE KEY STAGE 2

- Explain that unsupported objects fall towards the Earth because of the force of gravity acting between the Earth and the falling object
- Identify the effects of air resistance, water resistance and friction, that act between moving surfaces
- (Non-statutory) They should explore the effects of air resistance by observing how different objects such as parachutes and sycamore seeds fall
- (Non-statutory) Pupils might work scientifically by: designing and making a variety of parachutes and carrying out fair tests to determine which designs are the most effective
- Working scientifically: asking relevant questions and using different types of scientific enquiries to answer them
- Working scientifically: setting up simple practical enquiries, comparative and fair tests
- Working scientifically: making systematic and careful observations and, where appropriate, taking accurate measurements using standard units, using a range of equipment, including thermometers and data loggers
- Working scientifically: gathering, recording, classifying and presenting data in a variety of ways to help in answering questions
- Working scientifically: recording findings using simple scientific language, drawings, labelled diagrams, keys, bar charts, and tables
- Working scientifically: using results to draw simple conclusions, make predictions for new values, suggest improvements and raise further questions

MATHS KEY STAGE 2

- Measure, compare, add and subtract lengths (m/cm/mm); mass (kg/g); volume/capacity (l/ml)
- Convert between different units of measure [for example, kilometre to metre; hour to minute]

DESIGN & TECHNOLOGY KEY STAGE 2

- Use research and develop design criteria to inform the design of innovative, functional, appealing products that are fit for purpose, aimed at individuals or groups
- Generate, develop, model and communicate their ideas through discussion, annotated sketches, cross-sectional and exploded diagrams, prototypes, pattern pieces and computer-aided design
- Select from and use a wider range of tools and equipment to perform practical tasks [for example, cutting, shaping, joining and finishing], accurately
- Apply their understanding of how to strengthen, stiffen and reinforce more complex structures

INTRODUCTION

What is a Parachute?

Explain to students that: A parachute is a device used to slow the motion of an object through an atmosphere by creating air resistance/drag. Parachutes are usually made of light, strong fabric, originally silk, now most commonly nylon. They are typically dome-shaped, but vary, with rectangles, inverted domes, and others found.

There are two forces acting on a parachute with a parachutist: the force of gravity and the air resistance/drag.

What is a parachutist?

Explain to students that: A parachutist is a person that uses a parachute.

What is air resistance/drag?

Explain to students that: Air resistance or drag is the frictional force air exerts against a moving object. As an object moves, air resistance/drag slows it down. The faster the object's motion, the greater the air resistance exerted against it. Air resistance/drag affects all moving objects, from airplanes, rockets, and trains to car, bicycles, and even living things.

An object's shape and surface area can increase or decrease the degree of air resistance it encounters. A feather will fall more slowly than a metal ball because the feather has a greater surface area. Because it can spread its weight over a larger area, the feather encounters greater air resistance/drag and falls more slowly. This is the principle used in the parachute.

What is an Aerospace engineer?

Explain to students that: Aerospace engineers design, build, and test, machines that fly.

Newton's Laws of Motion (taught at key stage 3)

Explain to students that: Sir Isaac Newton was a brilliant mathematician, astronomer and physicist who was one of the most influential figures in human history. Newton studied a wide variety of phenomena during his lifetime, one of which included the motion of objects and systems. Based on his observations he formulated Three Laws of Motion. Newton's First Law – An object at rest will remain at rest and an object in motion will remain in motion at a constant speed unless acted on by an unbalanced force (such as friction or gravity). This is also known as the law of inertia. Newton's Second Law – An object's acceleration is directly proportional to the net force acting on it and inversely proportional to its mass. The direction of the acceleration is in the direction of the applied net force. Newton's Second Law can be expressed as: $F = ma$. Newton's Third Law – For every action there is an equal and opposite reaction.

Materials

- | | | |
|------------------|-------------------|------------------------------------|
| 1. CARDBOARD | 2. STRING/RIBBON | 3. SELLOTAPE |
| 4. SCISSORS | 5. BAMBOO SKEWERS | 6. EGG CARTON |
| 7. SANDWICH BAGS | 8. BUBBLE-WRAP | 9. 1 HARD-BOILED EGG (PARACHUTIST) |

MAIN ACTIVITY

- 1 Students will need to work in a minimum of two for this activity.
- 2 Explain that students must develop a parachute from everyday items, that can travel safely to earth.
- 3 Ask students to develop a plan for their parachute. They will need to decide and agree on the materials they will use, write/draw their plan, and present their plan to the class.
- 4 Show students the student activity sheet and explain that they will need to follow the instructions to make their parachute.
- 5 Student groups next execute their plans and build their parachute using the materials they have chosen. They may need to rethink their plan, request other materials, or start again if the materials chosen are not working.
- 6 Next, teams will test their parachute. To ensure that the parachute travels safely to earth.
- 7 Teams complete an evaluation / reflection worksheet, and present to the class.

PLENARY (QUESTIONS TO ASK STUDENTS)

1. Did you succeed in creating a parachute? If so, what height did it travel from? If not, why did it fail?
2. Which materials did you use for your parachute?
3. What is the average speed your parachute achieved?
4. How did you make sure that your parachute travelled safely to the ground?
5. Did you decide to revise your original design or request additional materials while in the construction phase? Why?
6. If you could have had access to materials that were different than those provided, what would your team have requested? Why?
7. Do you think engineers have to adapt their original plans during the construction of systems or products? Why might they?
8. If you had to do it all over again, how would your planned design change? Why?
9. What designs or methods did you see other teams try that you thought worked well?
10. Do you think you would have been able to complete this project easier if you were working alone? Explain...

STEM Day Risk Assessment

Risk Assessment for	Engineering at School Projects
Assessment undertaken on	31/03/2020
Assessment undertaken by	Jessica Lee
Signed	

No.	Activity/area being assessed	Associated risk	Who is at risk?	Existing control measures in place?	Level of risk (low, medium, high)	Responsibility
1	General Activity and Workspace	Slips, trips and falls: Injury due to tripping over items	Students and adults	Activity supervised by adult supervisor. Deliverer reminds students about safety in video introduction.	M	Students and adults
2	Use of Materials: paper/card, plastic containers	Injuries: Injury due to paper cuts, cuts from sharp edges Injuries: Injury due to misuse	Students and adults	Activity supervised by adult supervisor.	L	Students and adults
3	Use of materials: elastic bands, sellotape, glue stick, blu-tack, small toys, paper fasteners, LEGO pieces, nuts & bolts or equivalent.	Injuries: Injury due to use as a missile Slips, trips and falls: Injury due to slipping on dropped items Injuries: Ingestion risk of choking.	Students and adults Students and adults Students and adults	Activity supervised by adult supervisor. Activity supervised by adult supervisor. Activity supervised by adult supervisor.	L	Students and adults
4	Use of materials: plastic, corrugated cardboard	Injuries: Cuts from sharp edges	Students and adults	Activity supervised by adult supervisor.	L	Students and adults

No.	Activity/area being assessed	Associated risk	Who is at risk?	Existing control measures in place?	Level of risk (low, medium, high)	Responsibility
5	Use of sharp tools: Scissors, craft knives	Injuries: Cut to self Behaviour: Cut to others Behaviour: Vandalism of property	Students Students and adults School or home	Activity supervised by adult supervisor. Activity supervised by adult supervisor. Activity supervised by adult supervisor.	M L L	Students and adults Students and adults Students and adults
6	Testing of projects: bathtub, drop from height, items on floor	Spillage of water on floor: damage and injury due to slip Slip, trip or fall: Injury due to falling from testing area, tripping over items in testing space	Students and adults Students and adults	Activity supervised by adult supervisor. Activity supervised by adult supervisor.	L L	Students and adults Students and adults

The Smallpeice Trust
ENGINEERING
@SCHOOL

03

The
Parachute
Challenge

#EngineeringAtSchool

Suitable
for ages:

5+

Time
needed:

1hr+



smallpeice 
Dare to imagine

DESIGN A PARACHUTE

You are a team of engineers who have been given the challenge to design your own parachute out of everyday items.

The parachute needs to be able to travel safely to earth.



What is a Parachute?

A parachute is a device used to slow the motion of an object through an atmosphere by creating air resistance/drag. Parachutes are usually made of light, strong fabric, originally silk, now most commonly nylon. They are typically dome-shaped, but vary, with rectangles, inverted domes, and others found.

There are two forces acting on a parachute with a parachutist: the force of gravity and the air resistance/drag.

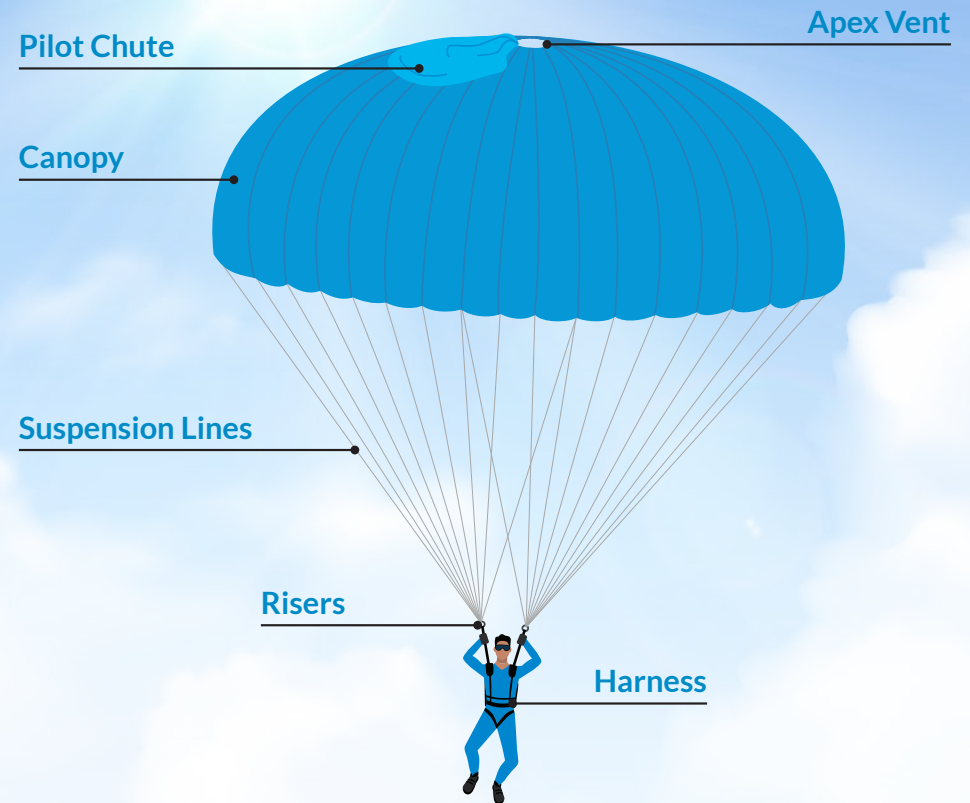

PLANNING STAGE

In your team, discuss the problem you need to solve. Then develop and agree on a design for your parachute. You'll need to decide and agree what materials you want to use.

Draw your design in the box shown on the right and label the different parts and materials you plan to use. Present your design to the class.

You may choose to revise your team's plan after you receive feedback from class.



PARACHUTE DESIGN & MATERIALS

MATERIALS

1. CARDBOARD
2. STRING/RIBBON
3. SELLOTAPE
4. SCISSORS
5. BAMBOO SKEWERS
6. EGG CARTON
7. SANDWICH BAGS
8. BUBBLE-WRAP
9. 1 HARD-BOILED EGG
(PARACHUTIST)



BUILDING STAGE

Build your parachute. During building you may decide you need additional materials or that your design needs to change.

- 1 Build your parachute. During building you may decide you need additional materials or that your design needs to change
- 2 Create a basket for your precious cargo. Make sure it can fit comfortably and can enter and exit freely
- 3 Create a parachute using a light material with a large surface area (we used sandwich bags)
- 4 Attach the basket to the parachute using string, ribbon or any material you can find
- 5 Test the parachute without the cargo from a very low height. You'll need to check that the parachute opens correctly and slowly falls to earth
- 6 When you are confident it will work, test the parachute with your cargo from a series of different heights

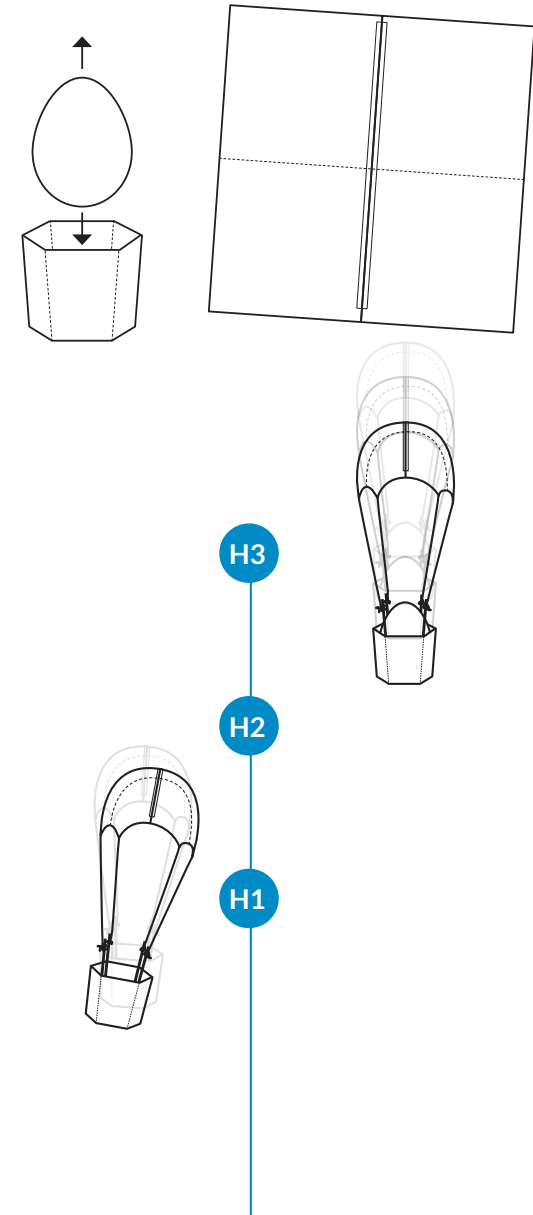

TESTING STAGE

Each team will test their parachute. Calculate the speed that your parachute falls.

$SPEED = \text{Distance} \div \text{Time}$.

For our example, the parachute travelled 4.5m in 1.1s
 $4.5 \div 1.1 = 4.2$ metres per second.
Be sure to watch the tests of the other teams and observe how their different designs worked.

PARACHUTE DATA

	Height	Time Travelled	Speed (m/s)
Test 1			
Test 2			
Test 3			
Average			

EVALUATION STAGE 1 OF 2

Evaluate your team's results, complete the evaluation worksheet, and present your findings to the class.

Use this worksheet to evaluate your team's results in the Parachute Challenge.

- 1. Did you succeed in creating a parachute?
If so, what height did it travel from?
If not, why did it fail?**

- 2. What is the average speed your parachute achieved?**

- 3. How did you make sure your parachute travelled safely to earth?**

- 4. What materials did you use to make you parachute and why?**

- 5. Did you decide to revise your original design or request additional materials while in the construction phase? Why?**

- 6. If you could have had access to materials that were different than those provided, what would your team have requested? Why?**

EVALUATION STAGE 2 OF 2

7. Do you think engineers have to adapt their original plans during the construction of systems or products? Why might they?

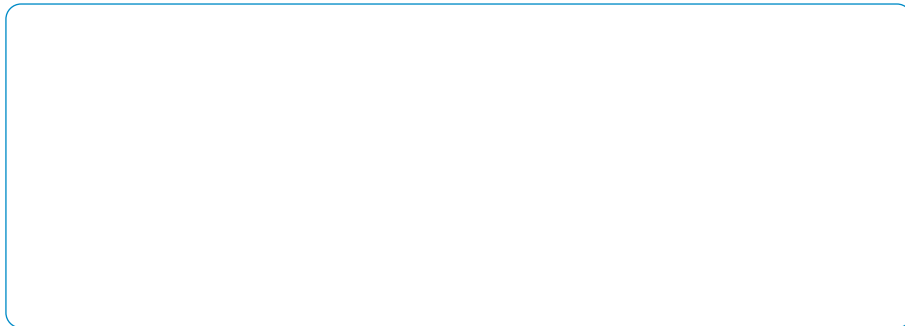

8. If you had to do it all over again, how would your planned design change? Why?

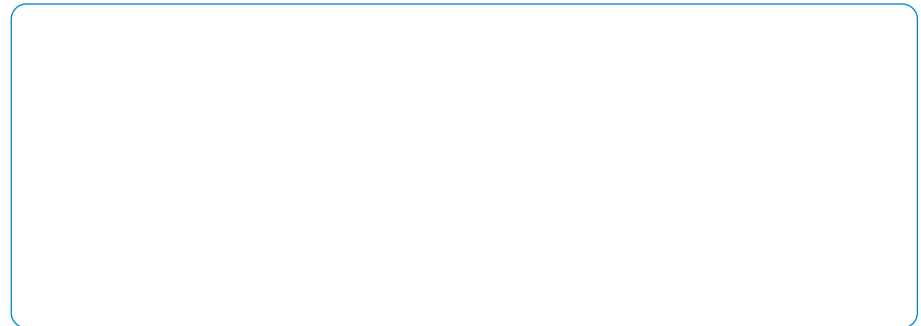

9. What designs or methods did you see other teams try that you thought worked well?

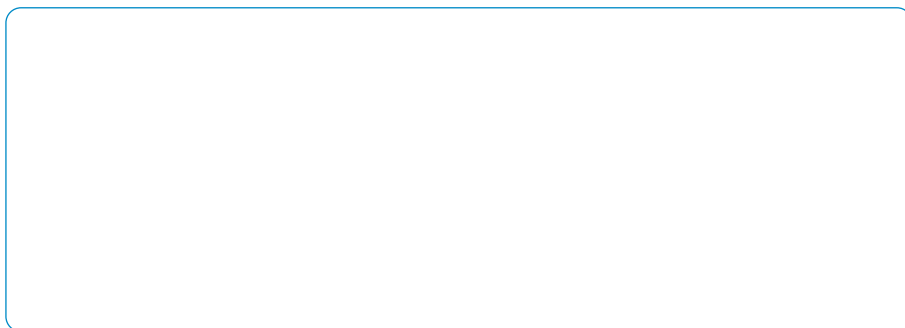

10. Do you think you would have been able to complete this project easier if you were working alone? Explain...

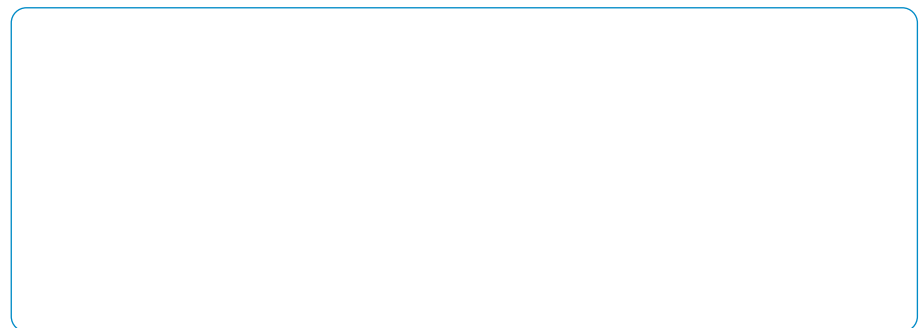

ADDITIONAL CHALLENGES

If you complete your paddle boat and want to challenge yourself further...

1 Try and find different materials. Can you **IMPROVE THE PERFORMANCE?** Can you **MAKE IT LIGHTER?**

2 Draw a force diagram showing the forces acting on the parachute

